

---

# isHMuxGate

MANUAL



# CERTIFICATE OF CONFORMITY

according to EC Directive 2014/30/EU (electromagnetic compatibility) of 26 February 2014.

We hereby declare, that the device indicated below in its design and construction, is in conformity with the essential safety and health requirements of the EC Directive 2014/30/EU.



**CHANGES OR MODIFICATIONS NOT APPROVED BY THORSIS TECHNOLOGIES VOID THE VALIDITY OF THE DECLARATION.**

Device type	Order number
isHMuxGate	14400-0101

**STANDARD USED:** DIN EN IEC 61326-1:2022-11

## Manufacturer

Thorsis Technologies GmbH  
Oststr. 18  
39114 Magdeburg  
Germany

Magdeburg, 2023-01-31

Dipl.-Inf. Michael Huschke,  
General Manager

# UK DECLARATION OF CONFORMITY

Thorsis Technologies GmbH declares as manufacturer under sole responsibility, that the products down in the list complies with the requirements of following UK legislation:

- S.I. 2019/1246 The Product Safety, Metrology and Mutual Recognition Agreement (Amendment)(EU Exit) regulations 2019
- S.I. 2020/852 The Product Safety and Metrology (Amendment)(EU Exit) regulations 2020
- S.I. 2016/1091 The Electromagnetic Compatibility Regulations 2016
- S.I. 2012/3032 The Restriction of the Use of Certain Hazardous Substances in Electrical and Electronic Equipment Regulations 2012

Device type	Order number
isHMuxGate	14400-0101



**CHANGES OR MODIFICATIONS NOT APPROVED  
BY THORSIS TECHNOLOGIES VOID THE VALIDITY  
OF THE DECLARATION.**

**STANDARDS USED:** DIN EN IEC 61326-1:2022-11  
**CERTIFICATION:** NONE

**Manufacturer**

Thorsis Technologies GmbH  
Oststr. 18  
39114 Magdeburg  
Germany

Magdeburg, January 31, 2023

Dipl.-Inf. Michael Huschke,  
General Manager

**UK  
CA**

---

# Table of Content

<b>1.</b>	<b>INTRODUCTION</b> . . . . .	<b>5</b>	<b>4.</b>	<b>INTEGRATION INTO ABB-FIM</b> . . . . .	<b>21</b>
<b>1.1</b>	<b>Dimensional Drawing</b> . . . . .	<b>5</b>	<b>4.1</b>	<b>Setup Installation</b> . . . . .	<b>21</b>
<b>1.2</b>	<b>Factory Reset</b> . . . . .	<b>6</b>	<b>4.2</b>	<b>Manage Certificates</b> . . . . .	<b>22</b>
<b>1.3</b>	<b>Technical details</b> . . . . .	<b>7</b>	<b>4.3</b>	<b>Installation of FDI Packages</b> . . . . .	<b>25</b>
<b>1.3.1</b>	<b>Channel assignment</b> . . . . .	<b>8</b>	<b>4.4</b>	<b>Adding the Communication Server</b> . . . . .	<b>27</b>
<b>1.3.2</b>	<b>Connection of one or more Multiplexers</b> . . . . .	<b>9</b>			
<b>2.</b>	<b>HARDWARE INSTALLATION</b> . . . . .	<b>10</b>	<b>5.</b>	<b>FDT/HMUXGATE DTM</b> . . . . .	<b>32</b>
<b>2.1</b>	<b>Safety instructions</b> . . . . .	<b>10</b>	<b>5.1</b>	<b>Setup Installation</b> . . . . .	<b>32</b>
<b>2.2</b>	<b>Specific conditions of use</b> . . . . .	<b>11</b>	<b>5.2</b>	<b>Start FDT Frame and update the device catalog</b> . . . . .	<b>33</b>
<b>2.3</b>	<b>Electrical installation</b> . . . . .	<b>11</b>	<b>5.3</b>	<b>Inset the HMuxGate</b> . . . . .	<b>34</b>
<b>3.</b>	<b>WEB INTERFACE</b> . . . . .	<b>12</b>	<b>5.4</b>	<b>Enter the IP address</b> . . . . .	<b>36</b>
<b>3.1</b>	<b>Configuration of the IP address</b> . . . . .	<b>12</b>	<b>5.5</b>	<b>Topology Scan</b> . . . . .	<b>38</b>
<b>3.2</b>	<b>Update of the firmware</b> . . . . .	<b>13</b>	<b>5.6</b>	<b>Offline view and Online view</b> . . . . .	<b>39</b>
<b>3.3</b>	<b>Soft-Restart</b> . . . . .	<b>13</b>			
<b>3.4</b>	<b>Password protection</b> . . . . .	<b>14</b>	<b>#6.</b>	<b>DOCUMENT HISTORY</b> . . . . .	<b>40</b>
<b>3.5</b>	<b>License key</b> . . . . .	<b>15</b>			
<b>3.5.1</b>	<b>Standard and Additional License key</b> . . . . .	<b>16</b>			
<b>3.6</b>	<b>Mux Mode</b> . . . . .	<b>17</b>			
<b>3.7</b>	<b>RS485 Settings</b> . . . . .	<b>17</b>			
<b>3.8</b>	<b>Device List Settings</b> . . . . .	<b>18</b>			
<b>3.9</b>	<b>Mux Types</b> . . . . .	<b>18</b>			
<b>3.10</b>	<b>Multiplexer List</b> . . . . .	<b>19</b>			
<b>3.11</b>	<b>Device List</b> . . . . .	<b>20</b>			

# 1. Introduction

The isHMuxGate is an Ethernet gateway for the connection of RS485-HART multiplexers to an Ethernet network. The gateway translates from the Ethernet HART-IP protocol into the RS485 protocols of different multiplexer vendors.

## 1.1 Dimensional Drawing

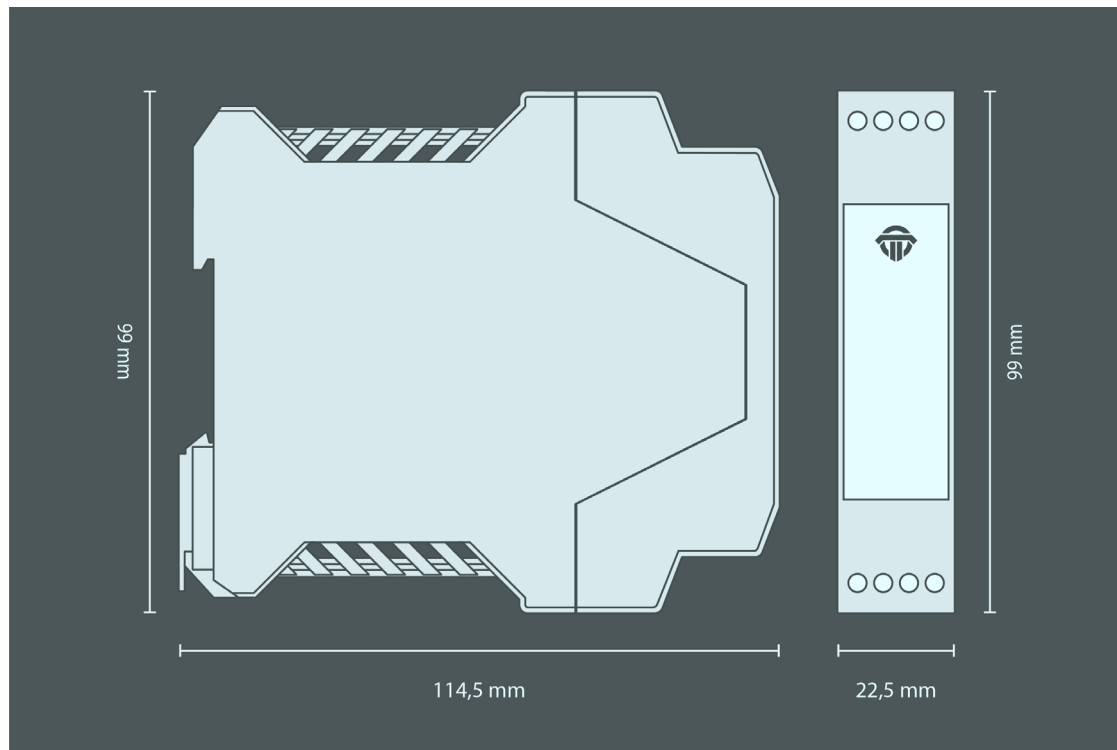

## 1.2 Factory Reset

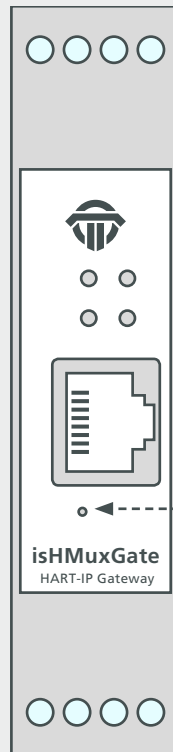

It may happen that a user needs to reset all settings to factory default. For example someone changed the IP address or the password and did not remember. Or the IP address was set to DHCP and there is no DHCP service available. In all these cases the user can reset the hardware back to firmware defaults by using the reset button. This button is located behind a small hole next to the RJ45 connector.

As a result of a firmware reset, the gateway will have its default IP address 192.168.0.10 and all other settings are back to factory default.

### 1.3 Technical details

isHMuxGate	
Order code	14400-0101
Processor	ATSAMA5D27C
RAM	64 MByte or 128 MByte
Flash	256 MByte
Transmission rate	<u>Ethernet</u> : 10 Mbit/s – 100 Mbit/s <u>RS-485</u> : 9,6 kBit/s, 19,2 kBit/s, 38,4 kBit/s
Power supply	10,8V .. 30V DC
Power consumption	50mA (typ. at 24V DC)
Galvanic isolation	yes
Protection class	IP20
Body material	Polyamide
Dimensions (L x W x H)	114,5mm x 99mm x 22,5mm
Weight	approx. 110g
Operating temperature	- 40 .. 70°C
Storage temperature	- 40 .. 85°C

### 1.3.1 Channel assignment

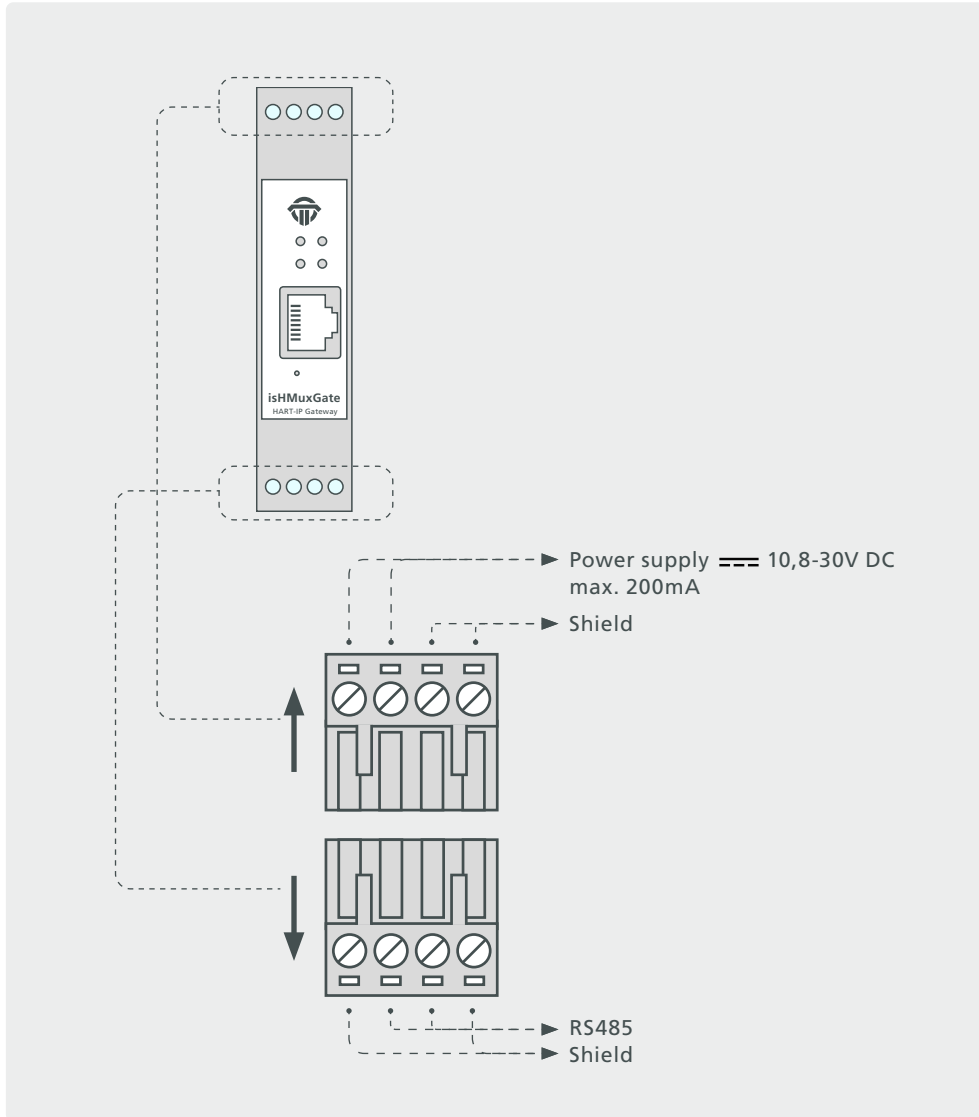

1.3.2 Connection of one or more Multiplexers

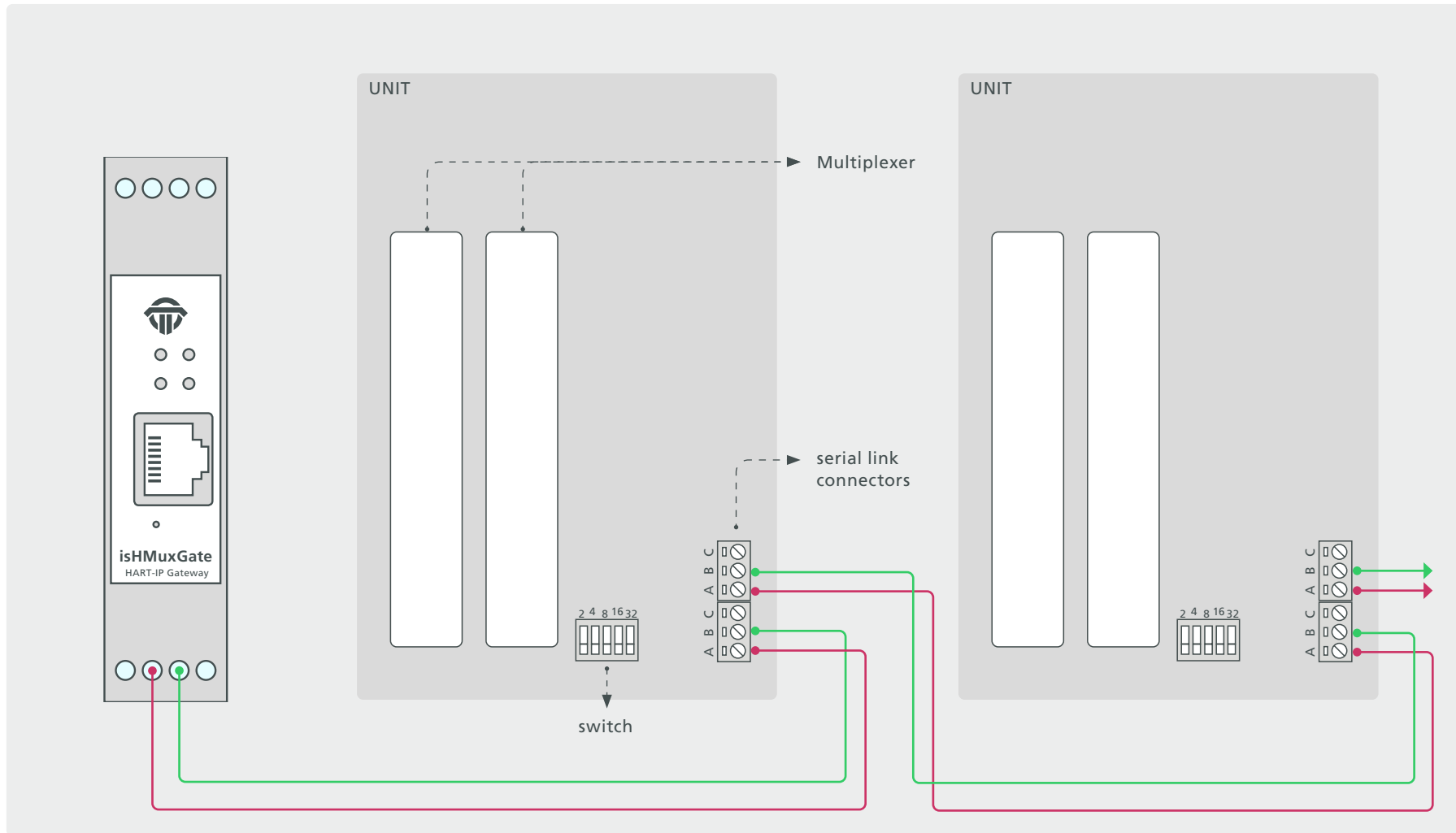

---

## 2. Hardware installation

---

### 2.1 Safety instructions



#### Installation notes

**Installation, operation and maintenance must be made by qualified personnel only and in accordance with your local and national technical regulations and safety directives.**

**Do not repair the device yourself, but replace it with an equivalent device. Repairs may be performed by the manufacturer only.**

**The manufacturer is not legally responsible for damage resulting from failure to comply.**

## 2.2 Specific conditions of use



**The equipment shall be installed in an enclosure that provides a degree of protection not less than IP 54 in accordance with IEC/EN 60079-15 and that have been considered to be not accessible in normal operation without the use of a tool.**

Transient protection shall be provided that is set at a level not exceeding 140 % of the peak rated voltage value at the supply terminals to the equipment.

The gateway must be mounted vertically on a 35 mm DIN rail.



**The gateway is HMuxGate is an open system and in accordance with UL/CSA approval an “open type.”  
The gateway have to be installed in a control cabinet, appropriate housing or a closed electrical operation room accessible only to authorized maintenance staff.**

---

## 2.3 Electrical installation



**Before installation of the modules and wiring make sure that the system is off power.**



**To supply the modules only power supplies with a secure electrically isolated extra-low voltage (SELV) may be used.**



**Cable entries and field wiring must be suitable for an operating temperature of at least +20° C above ambient.**

## 3. Web interface

### 3.1 Configuration of the IP address

The screenshot shows the THORSIS isHMuxGate status information page. The left sidebar contains a menu with items: System, Status, Network, Firmware, Restart, License Key, Password, Syslog, Settings, and Mux Mode. The main content area is titled 'isHMuxGate status information' and is divided into two columns: 'Hardware details' and 'Network details'.

Hardware details		Network details	
Serial number:	40E30A2	IP address:	192.168.10.75 (DHCP off)
MAC address:	6E:F8:04:0E:30:A2	Subnet mask:	255.255.255.0
Firmware version:	v2023.06.0	Default gateway:	192.168.10.1
Uptime:	0 days, 0 hours, 46 minutes	Hostname:	mxg-2

The default address of the gateway is: 192.168.0.10 subnet mask 255.255.255.0 Use your favorite browser to go the IP Address of your isHMuxGate. You should see this website. This is an overview over the current status.

Click on „Network Settings“ and you will get to the configuration mask.

The screenshot shows the THORSIS isHMuxGate Network Settings page. The left sidebar contains a menu with items: System, Status, Network, Firmware, Restart, License Key, Password, Syslog, Settings, Mux Mode, RS-485, Device List, HART-IP, and Mux Types. The main content area is titled 'Network Settings' and contains the following fields and options:

- Hostname:
- IP address:
- Subnet mask:
- Default gateway:
- Manual address assignment
- Automatic address assignment (DHCP)
- Submitting forces reboot
- 

Here you can change the Hostname, the IP Address, the subnet mask and the default Gateway. You can also choose to set the IP Address manually or with your DHCP Server. Pressing the Submit button applies the changes and restarts the gateway.

## 3.2 Update of the Firmware

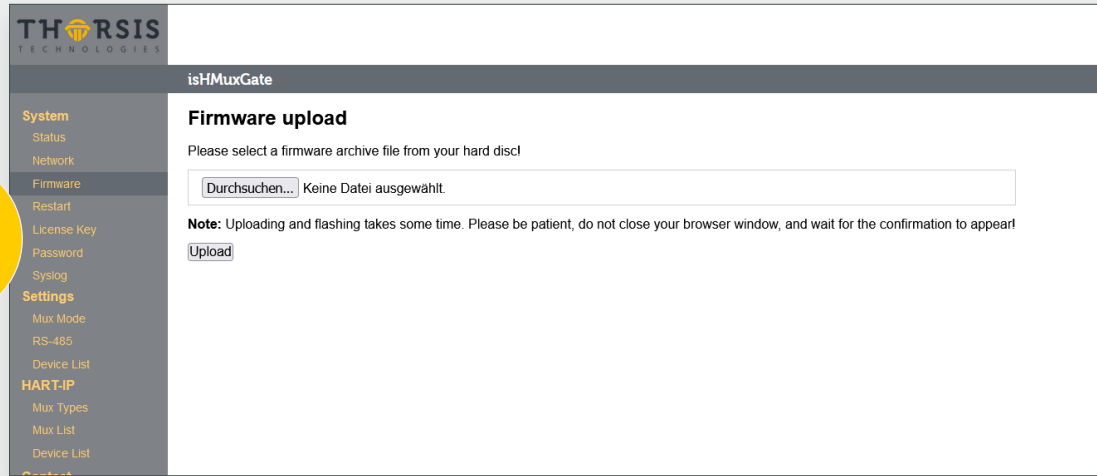

If a new firmware is available for your device you can flash it using the web interface. Go to the Menu Firmware and select the file you want to flash. Click the Upload button and wait until a confirmation appears that the upload was successful.

After the successful update, the isHMuxGate must be restarted by using the Restart-function in the Web interface.

## 3.3 Soft-Restart

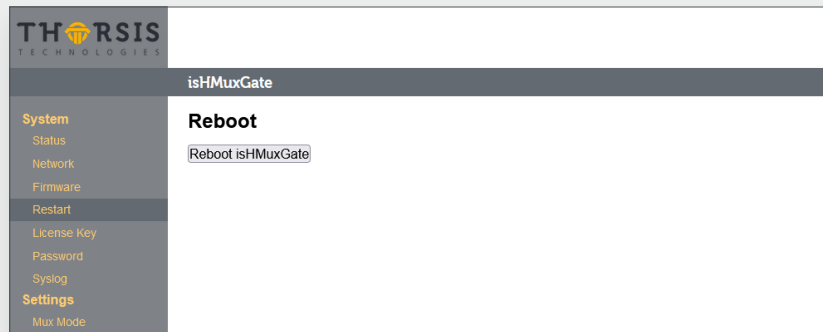

To restart the gateway, go to the Restart menu and press the button Reboot.

## 3.4 Password protection

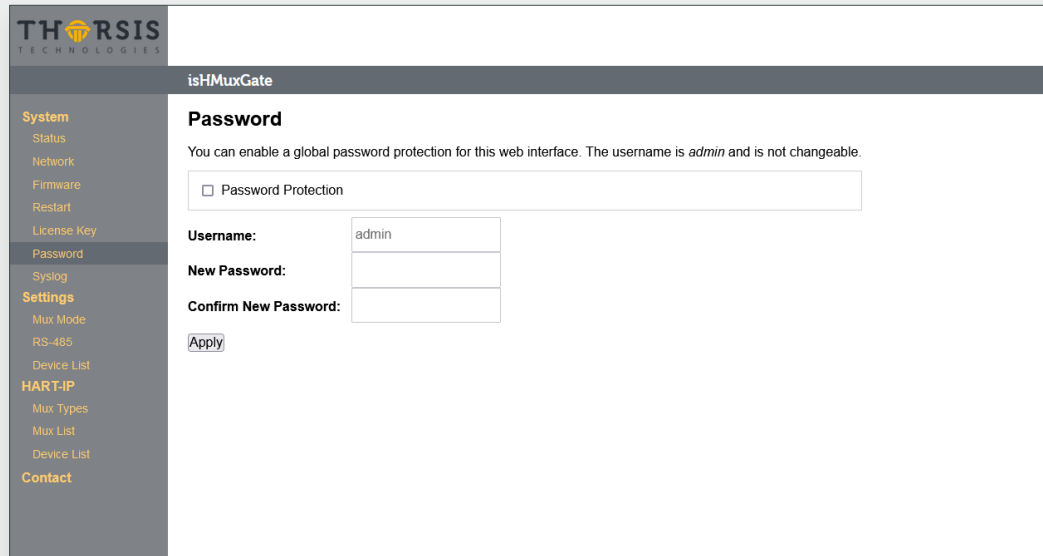

The screenshot shows the THORSIS TECHNOLOGIES web interface for isHMuxGate. The left sidebar contains a navigation menu with categories: System (Status, Network, Firmware, Restart, License Key, Password, Syslog), Settings (Mux Mode, RS-485, Device List), HART-IP (Mux Types, Mux List, Device List), and Contact. The main content area is titled "Password" and includes the following text: "You can enable a global password protection for this web interface. The username is *admin* and is not changeable." Below this text is a checkbox labeled "Password Protection". Underneath the checkbox are three input fields: "Username:" with the value "admin", "New Password:", and "Confirm New Password:". At the bottom of the form is an "Apply" button.

To enable a global password protection for the isHMuxGate web interface, click on the Password menu on the left. Activate the Password protection by clicking in the checkbox. Enter your password and repeat it in the field below.

Click Apply to confirm your settings.

Please note, that the username is always *admin* and can not be changed.

## 3.5 License key

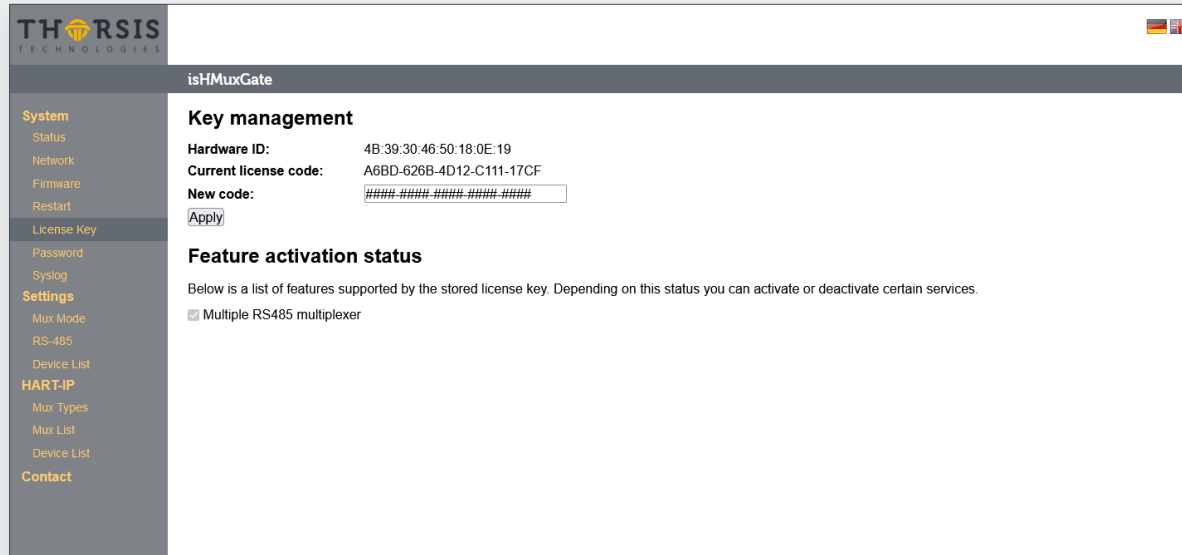

In the standard version the isHMuxGate is capable of connecting one single HART multiplexer to an HART-IP network. In order to connect more than one HART multiplexer to an HART-IP network, an additional license is required (see next page). It is possible to order the gateway together with the license, then this functionality is already enabled.

But it is also possible to purchase the gateway in the standard version and - when needed - to purchase the license key at a later time. The user can then enter the license key into the web page and enable additional features, i.e. enable support of more than one multiplexer connected to the gateway.

3.5.1 Standard and Additional License key

**Standard license:**  
connecting one single HART multiplexer to an HART-IP network

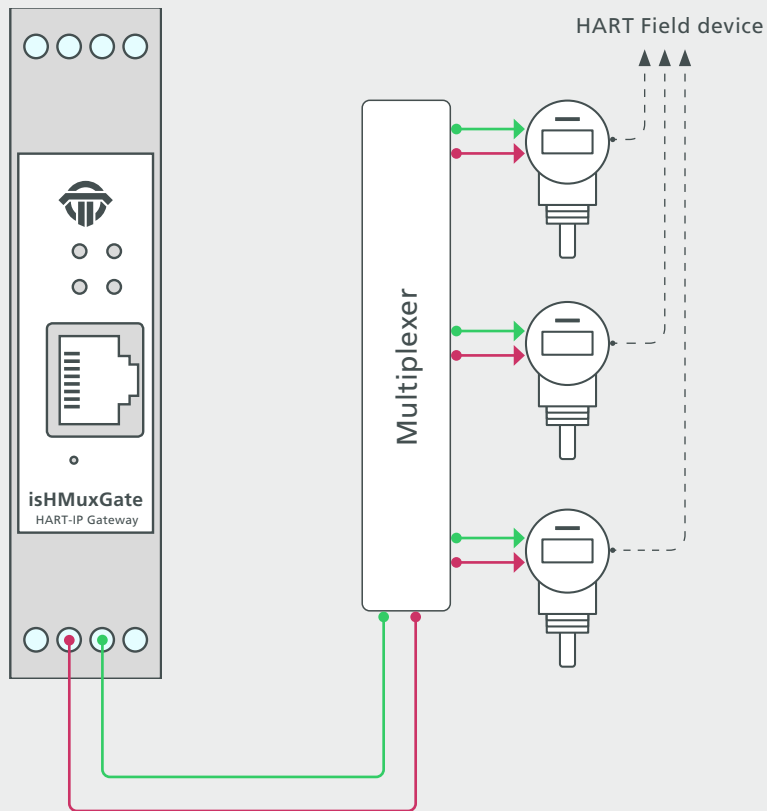

**Additional license:**  
connecting more than one HART multiplexer to an HART-IP network

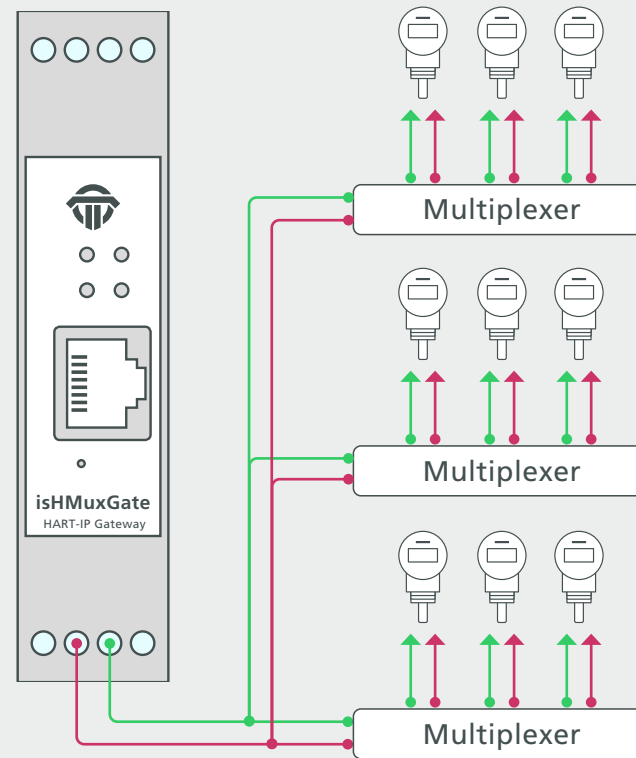

## 3.6 Mux-Mode

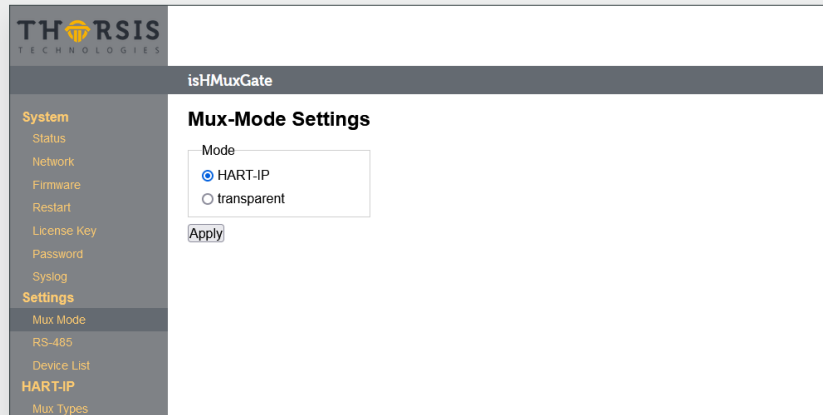

Usually the isHMuxGate translates all the protocols of different HART multiplexers into HART-IP.

But it is also possible to disable the HART-IP protocol. In the transparent mode all the gateway does is to forward all incoming characters received on TCP side to RS485 and vice versa.

## 3.7 RS485 Settings

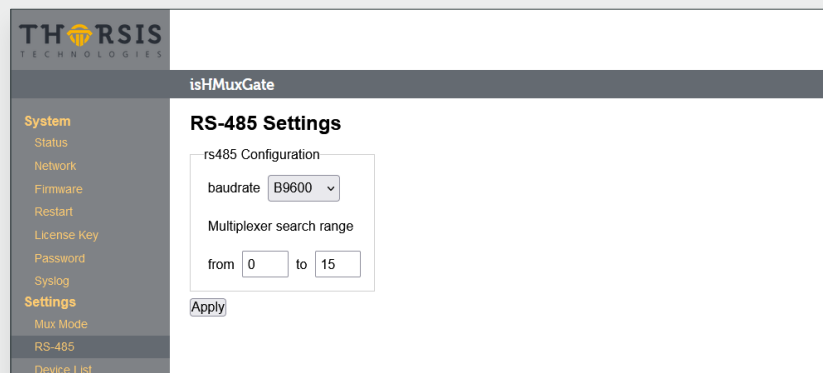

On this page the user can set the baud rate on the RS485 connection to the HART multiplexers.

Furthermore the user can select the address range of the HART multiplexers.

### 3.8 Device List Settings

The isHMuxGate keeps track of all HART instruments wired to the connected HART multiplexers. The user can select between single drop and multidrop but he can also disable searching for HART devices at all. Note: if disabled, then no HART devices can be shown in the device list (see chapter „Device List“ on page 20).

### 3.9 Mux Types

ID	Description	Protocol	
3c01	Arcom Control System	Arcom	✘
4015	Measurement Technology MTL4841 Multiplexer	MTL	✘
40ef	MTL 4850	Arcom	✘
49ed	Elcon Instruments Mux 2700-F	Arcom	✘
5de6	PEPPERL+FUCHS MUX2700-G	Arcom	✘
5def	PEPPERL+FUCHS KFD2-HMM-16	Arcom	✘
9e06	R. Stahl IS pac 9192 16 ch	Stahl	✘
9e07	R. Stahl IS pac 9192 32 ch	Stahl	✘
e3a4	GMI 5700	GMI	✘
9e05	I.S. 1 Remote I/O	Stahl	✘
9e78	9442	Stahl	✘
1982	new device	-- select protocol --	

The isHMuxGate contains a list with known HART multiplexers. If necessary additional HART multiplexers can be added to this list. In order to do so, the user needs to enter the Expanded Device Type ID and select the protocol which the multiplexer is using on RS485 for communication.

### 3.10 Multiplexer List

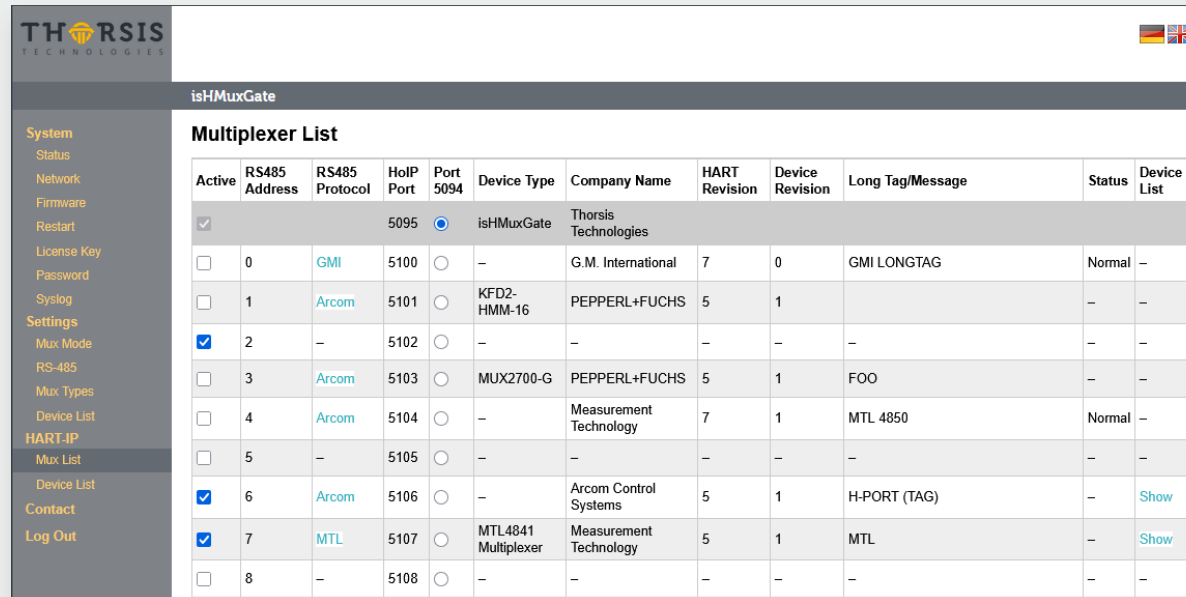

The screenshot shows the 'isHMuxGate' web interface. On the left is a navigation menu with options like System, Network, Firmware, Restart, License Key, Password, Syslog, Settings, Mux Mode, RS-485, Mux Types, Device List, HART-IP, Mux List, Device List, Contact, and Log Out. The main content area is titled 'Multiplexer List' and contains a table with the following columns: Active, RS485 Address, RS485 Protocol, HoIP Port, Port 5094, Device Type, Company Name, HART Revision, Device Revision, Long Tag/Message, Status, and Device List. The table lists several multiplexers, with rows 6 and 7 checked in the 'Active' column.

Active	RS485 Address	RS485 Protocol	HoIP Port	Port 5094	Device Type	Company Name	HART Revision	Device Revision	Long Tag/Message	Status	Device List
<input checked="" type="checkbox"/>			5095	<input checked="" type="radio"/>	isHMuxGate	Thorsis Technologies					
<input type="checkbox"/>	0	GMI	5100	<input type="radio"/>	–	G.M. International	7	0	GMI LONGTAG	Normal	–
<input type="checkbox"/>	1	Arcom	5101	<input type="radio"/>	KFD2-HMM-16	PEPPERL+FUCHS	5	1		–	–
<input checked="" type="checkbox"/>	2	–	5102	<input type="radio"/>	–	–	–	–	–	–	–
<input type="checkbox"/>	3	Arcom	5103	<input type="radio"/>	MUX2700-G	PEPPERL+FUCHS	5	1	FOO	–	–
<input type="checkbox"/>	4	Arcom	5104	<input type="radio"/>	–	Measurement Technology	7	1	MTL 4850	Normal	–
<input type="checkbox"/>	5	–	5105	<input type="radio"/>	–	–	–	–	–	–	–
<input checked="" type="checkbox"/>	6	Arcom	5106	<input type="radio"/>	–	Arcom Control Systems	5	1	H-PORT (TAG)	–	Show
<input checked="" type="checkbox"/>	7	MTL	5107	<input type="radio"/>	MTL4841 Multiplexer	Measurement Technology	5	1	MTL	–	Show
<input type="checkbox"/>	8	–	5108	<input type="radio"/>	–	–	–	–	–	–	–

On this page the isHMuxGate shows all HART multiplexers connected to this gateway. The number of multiplexers shown here depends on the „Multiplexer search range“ in the RS485 settings (see chapter 3.7 „RS485 Settings“ on page 17).

In this multiplexer list the user can select, which of these multiplexers to use for HART-IP communication by ticking the boxes in the „Active“ column. In the standard version the user can select only one RS485 multiplexer. If using the license key, then the user can select multiple multiplexers.

Every multiplexer has its own HART-IP port assigned. HART-IP clients can connect to the multiplexers by using these port numbers as shown in the „HoIP port“ column. Additionally the user can select the multiplexer that the HART-IP standard port 5094 is related to.

## 3.11 Device List

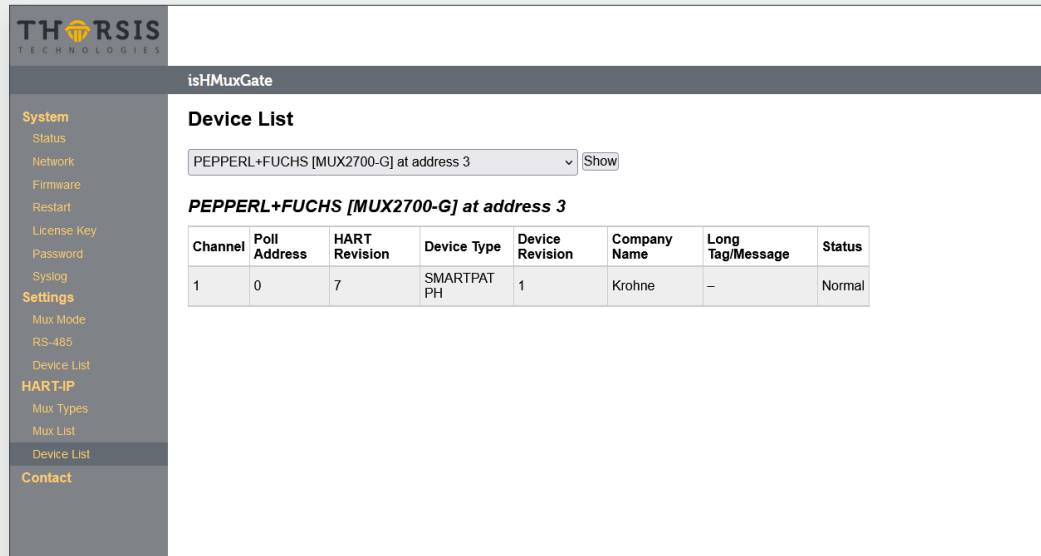

The screenshot displays the THORSIS isHMuxGate web interface. On the left is a navigation menu with categories: System (Status, Network, Firmware, Restart, License Key, Password, Syslog), Settings (Mux Mode, RS-485, Device List), HART-IP (Mux Types, Mux List, Device List), and Contact. The main content area is titled 'isHMuxGate' and 'Device List'. A dropdown menu shows 'PEPPERL+FUCHS [MUX2700-G] at address 3' with a 'Show' button. Below this, the text '**PEPPERL+FUCHS [MUX2700-G] at address 3**' is displayed. A table lists the connected HART devices:

Channel	Poll Address	HART Revision	Device Type	Device Revision	Company Name	Long Tag/Message	Status
1	0	7	SMARTPAT PH	1	Krohne	–	Normal

On this page the isHMuxGate shows the HART devices currently connected to the HART multiplexers.

## 4. Integration into the ABB FIM

### 4.1 Setup Installation

The hardware supplied also includes a USB stick containing the necessary installation files (zip).

In the first step, please install the following program file after unpacking: "HMUXGate FDI CommServer Setup.msi".

#### Start of the Installation:

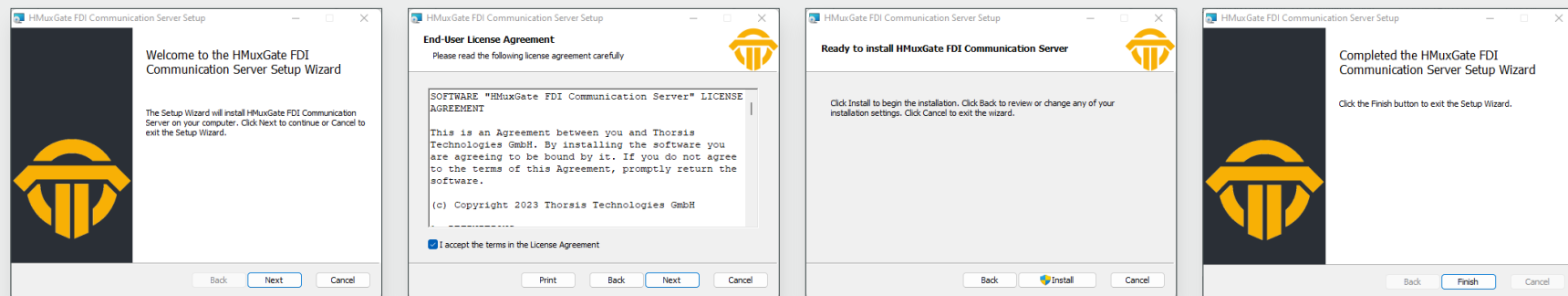

#### End of the Installation:

Please check the correct installation of the HMuxGate CommunicationServer on your computer.

The HMuxGate CommunicationServer is displayed under Services. (Status = running / Starttype = automatic)

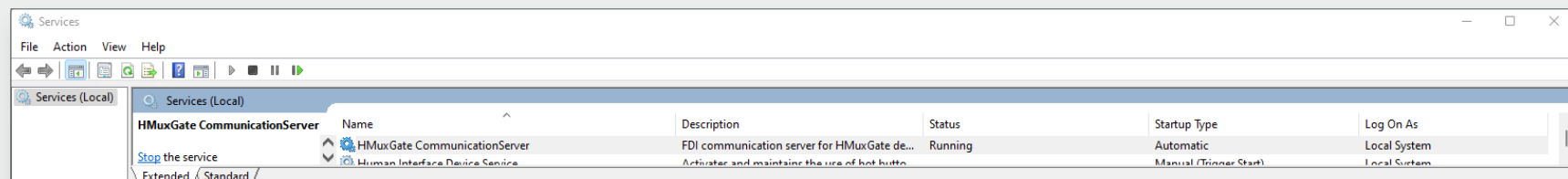

## 4.2 Manage Certificates

Start the ABB Field Information Manager  
Open the settings and select “CLIENT/SERVER SETTINGS”:

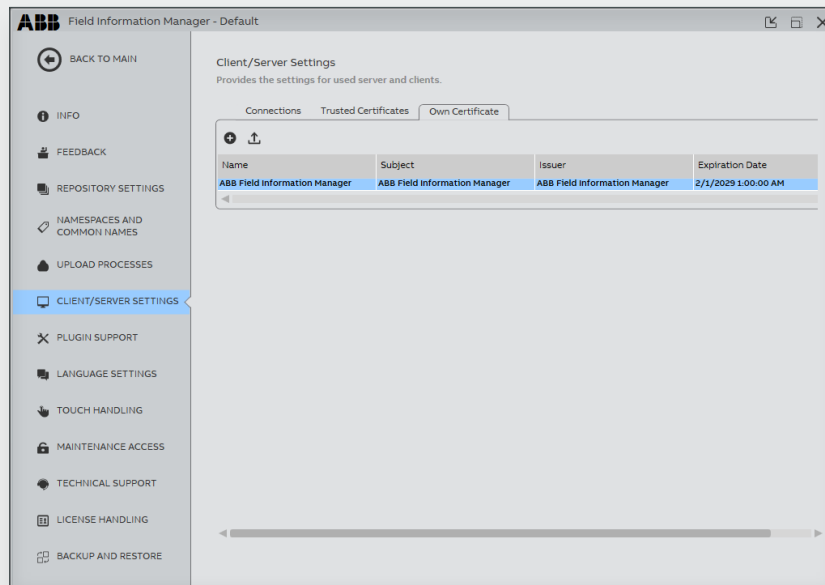

Select the “Own Certificate” tab and mark the “ABB Field Information Manager” certificate, then click on the upload icon.

Store the certificate on the desktop, for example:

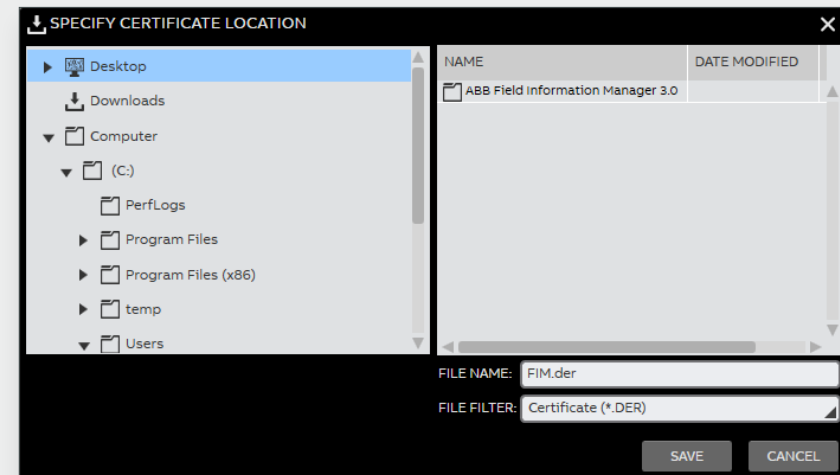

Now copy the certificate from the desktop and into the directory:

C:\ProgramData\Thorsis Technologies\HMuxGateFdiCommServer\TrustedCertificates:

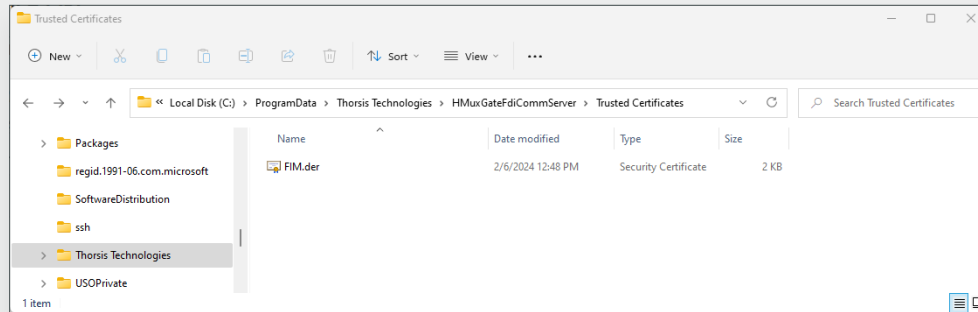

Copy the certificate from the HMuxGate FDI CommServer from the directory:

C:\ProgramData\Thorsis Technologies\HMuxGateFdiCommServer\CertificateStore\certs:



And place it on the desktop, for example:

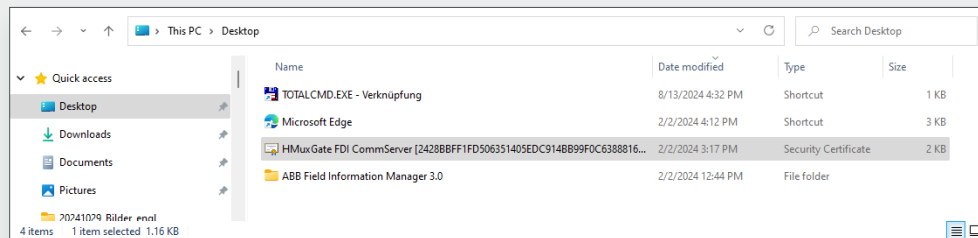

Open the FIM settings and select "CLIENT/SERVER SETTINGS"

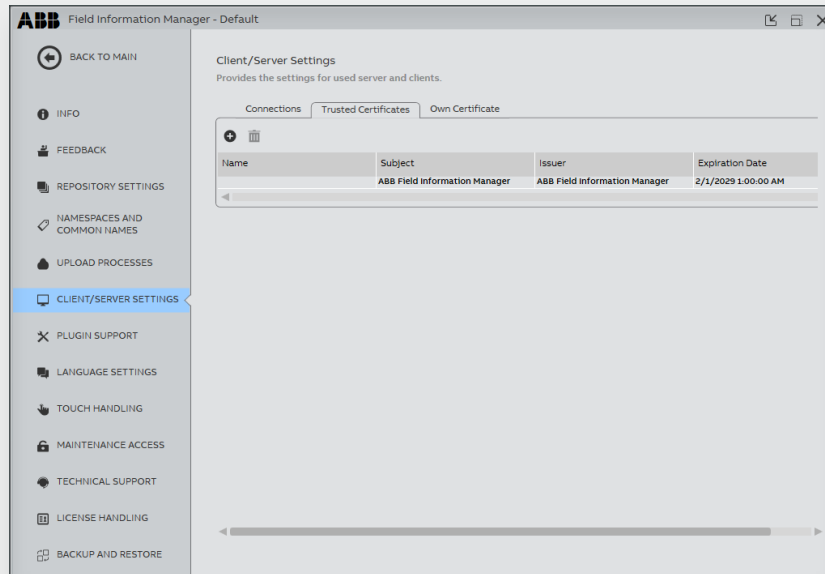

The certificate has now been saved.

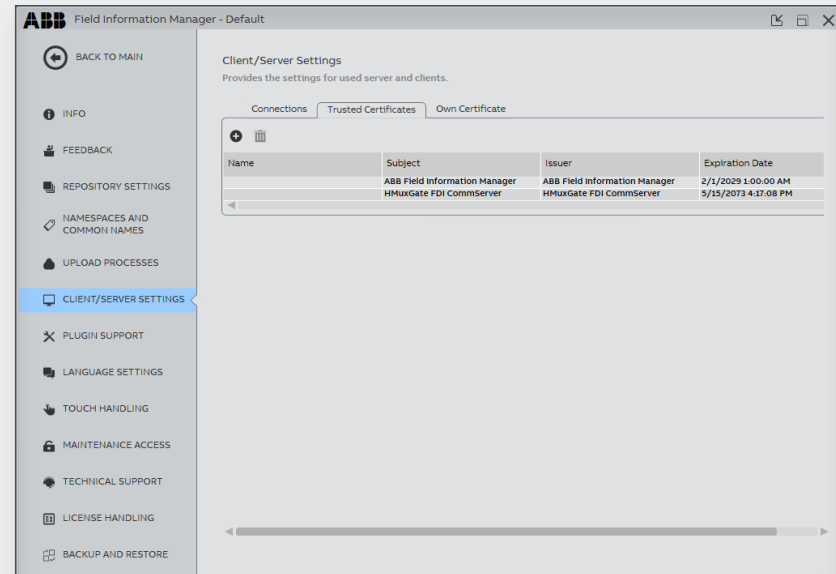

Select the „Trusted Certificates“ tab and select the „+“ symbol on the left and then choose the „HMMuxGateFdiCommServer“ certificate from the desktop:

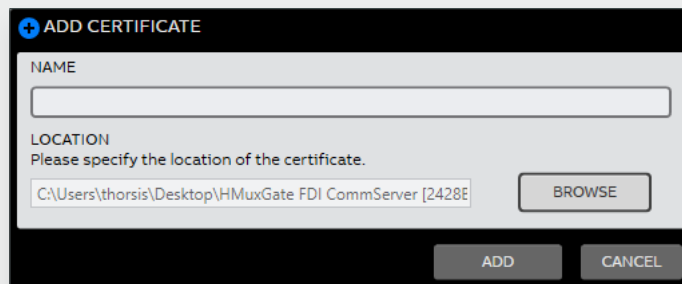

And confirm with „ADD“

### 4.3 Installation of FDI Packages

After installing the certificates, start the ABB FIM to add the two packages supplied on the stick to the device catalog.

- Thorsis.HartIpMultiplexerFimlet.1.0.5.fimlet<sup>1</sup>
- Thorsis.HMuxGate\_FDI\_Communication\_Server.1.0.5.HART.fdux<sup>1</sup>

When FIM is started, open the device catalog:



Press the “Import” button:

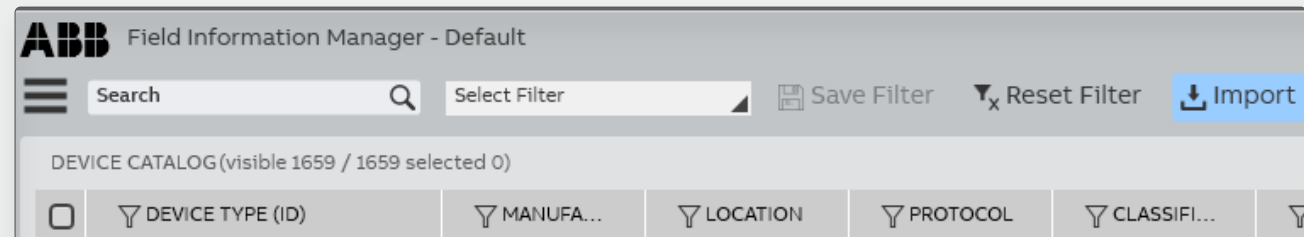

<sup>1</sup>Version numbers in the file name may differ depending on the time of installation.

Select the two files for the import:



When the import is done, a message indicates the status:

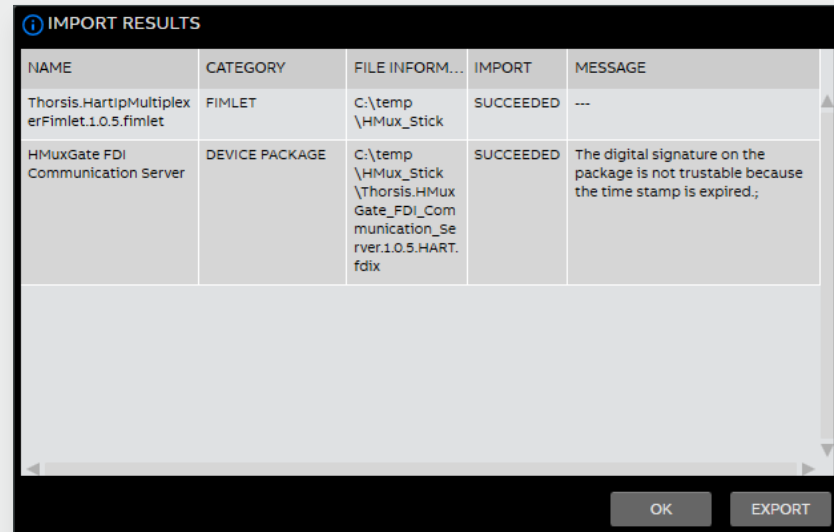

### 4.4 Adding the Communication Server

Close the device catalog and switch to Topology and click the "Add Server" button in FIM's main window:

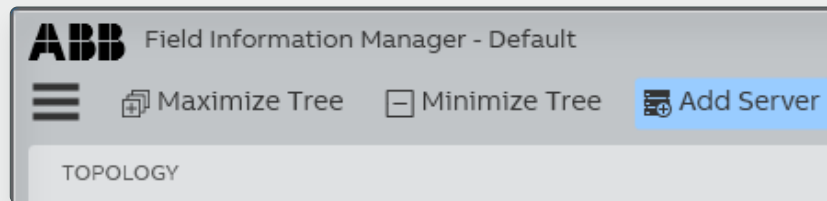

Select the Thorsis HMuxGate Communication Server and set the IP address to "localhost". Confirm the entry with "ADD".

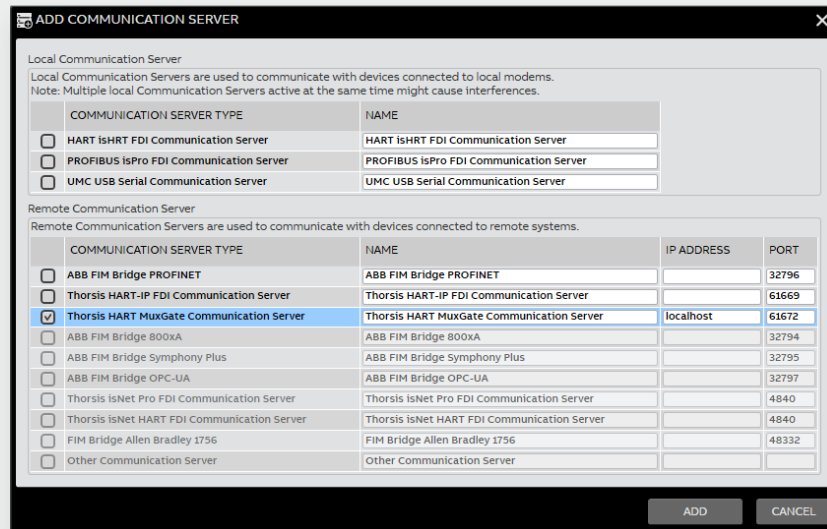

Click "OK" to confirm the successful addition of the Thorsis HART MuxGate Communication Server.

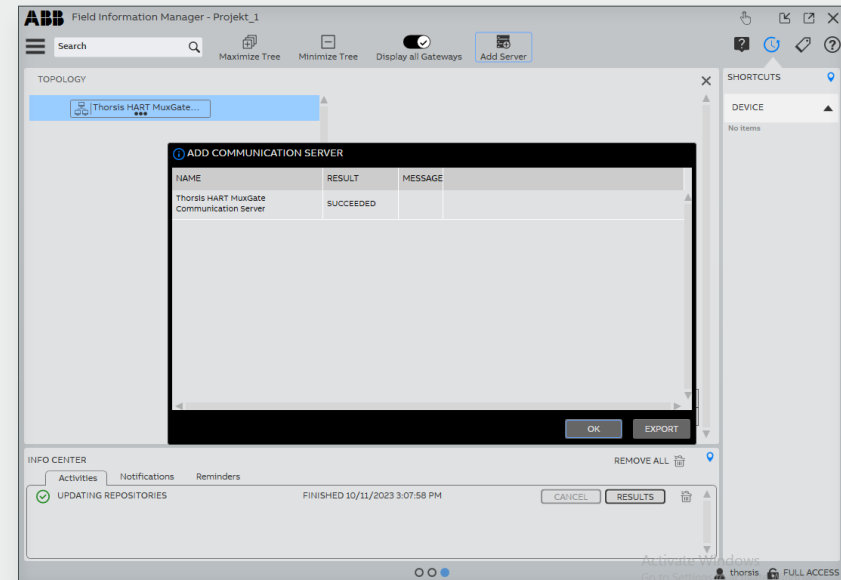

The Thorsis HMuxGate server can now be seen in TOPOLOGY:

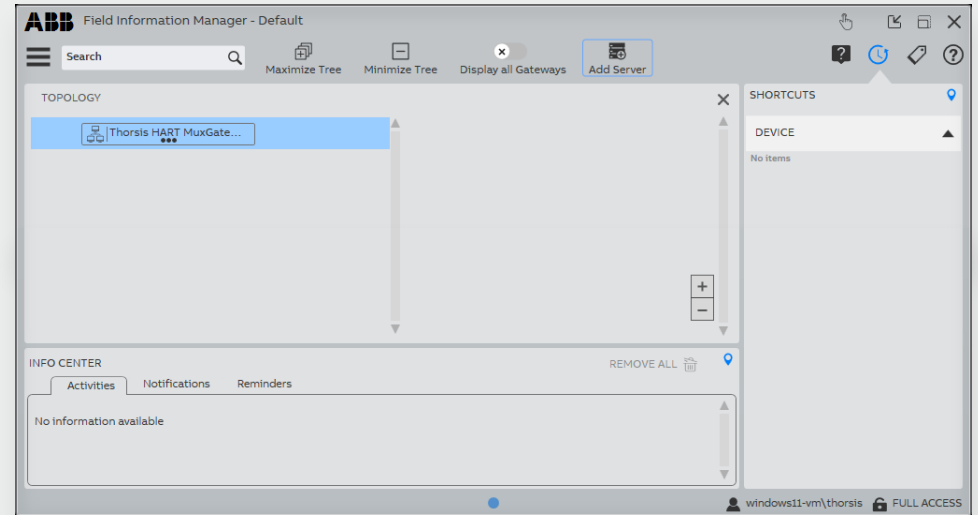

Right-click to open the window "DEVICE SETTINGS" WINDOW:

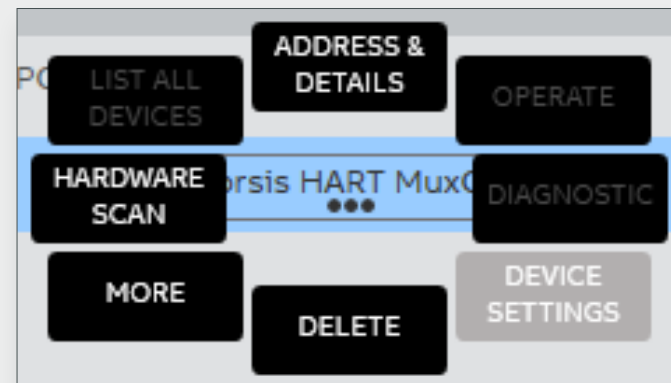

This window with the active HMuxGate is displayed as confirmation:

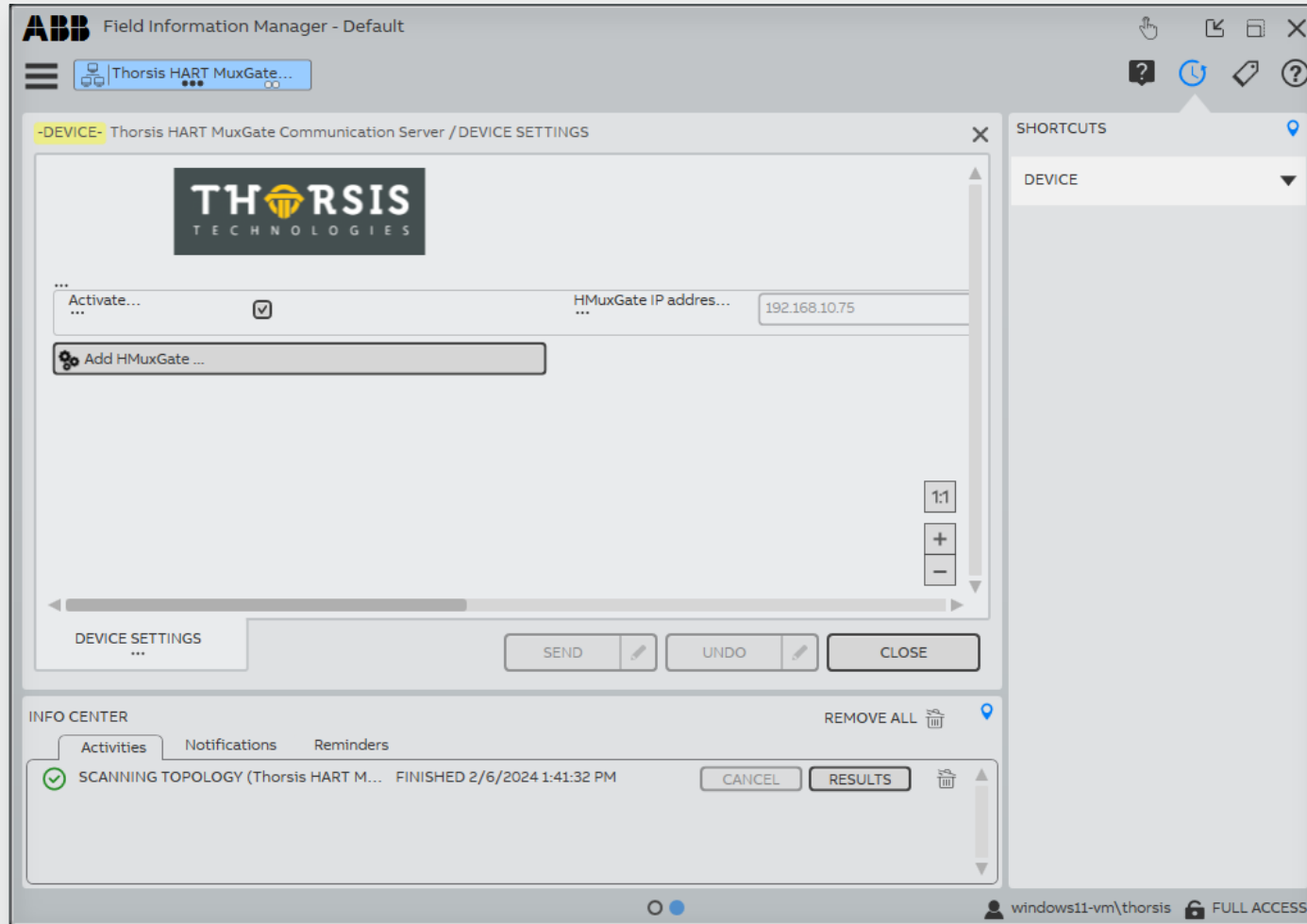

Start a hardware scan to detect connected devices and/or change settings for the communication server:

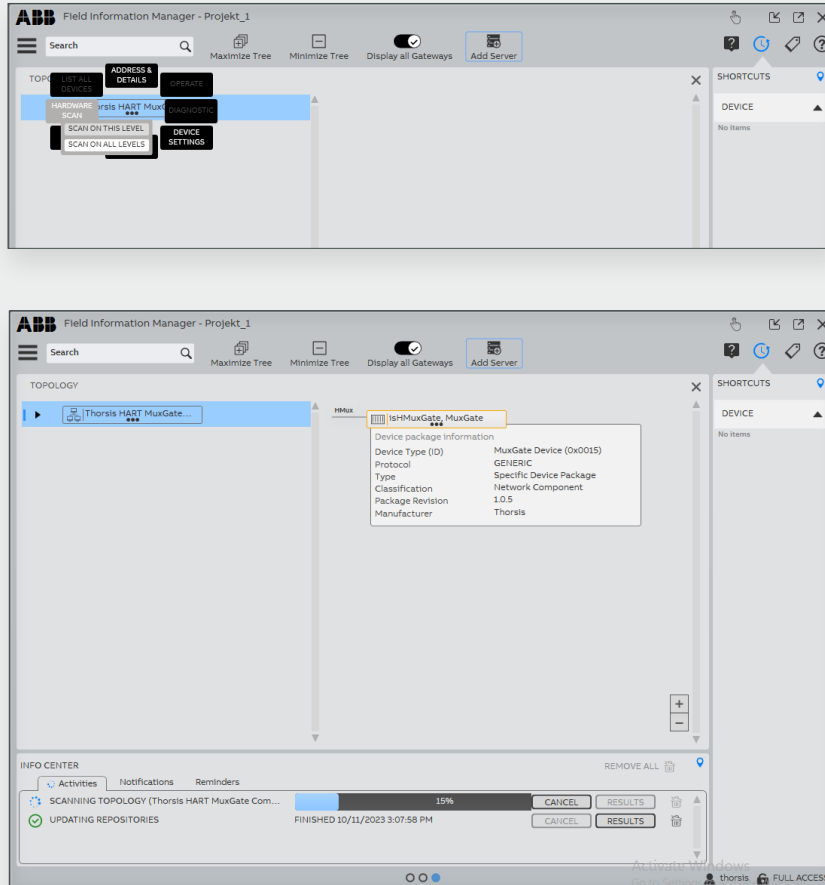

The active HMuxGates and HART multiplexers are found and listed. The connected HART devices are displayed under the modules.

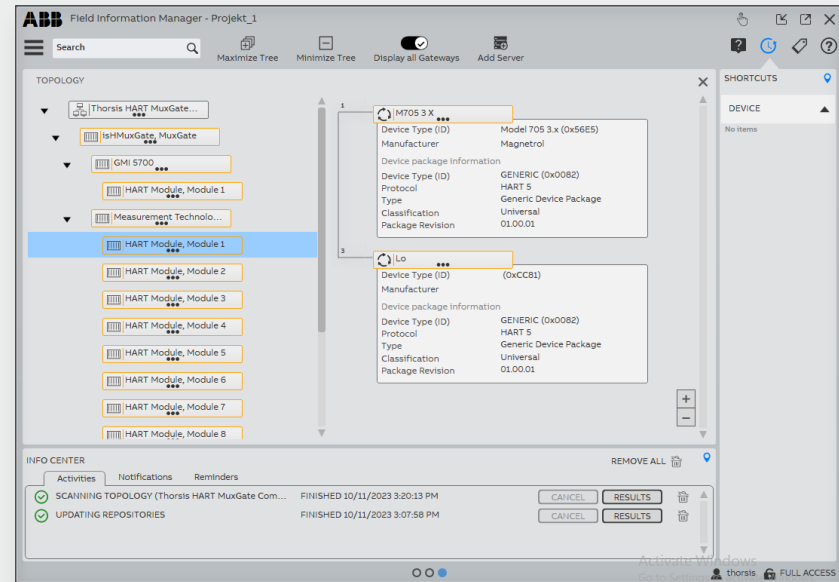

You can then use the HART Device Package to parameterize or monitor the devices online

The screenshot displays the ABB Field Information Manager (FIM) interface for a device named "M705 3 X". The interface is divided into several sections:

- Header:** "ABB Field Information Manager - Projekt\_1" with a search bar containing "M705 3 X".
- Navigation:** "Overview", "Signal view", and "Trend" tabs.
- Process variables:** A panel on the left showing input fields for "Process value" (0.000 in), "PV % range" (0.000 %), and "Loop current" (22.000 mA).
- Process variables (Charts):** Three small bar charts showing "PV digital value [in]", "PV % [%]", and "Current Output [mA]".
- Trend View:** A large chart at the bottom showing "Current Output [mA]" and "PV digital value [in]" over time. The x-axis ranges from 3:22:27 to 3:23:12. A yellow dashed line is visible at the top of the chart, and a value of "1.1" is shown at the end of the timeline.
- Shortcuts Panel:** A sidebar on the right titled "SHORTCUTS" with a "DEVICE" section containing a list of checkboxes: "DAMPING", "DATE", "LOWER RANGE VALUE", "PROCESS VALUE", "TAG", "UNIT", "UPPER RANGE VALUE", and "WRITE PROTECTION".
- Buttons:** "SEND", "UNDO", and "CLOSE" buttons are located at the bottom of the main window.

## 5. FDT / HMuxGate DTM

### 5.1 Setup Installation

The hardware supplied also includes a USB stick containing the necessary installation files (zip.).

In the first step, please install the following program file after unpacking: "HMUXGate DTMs Setup.msi".

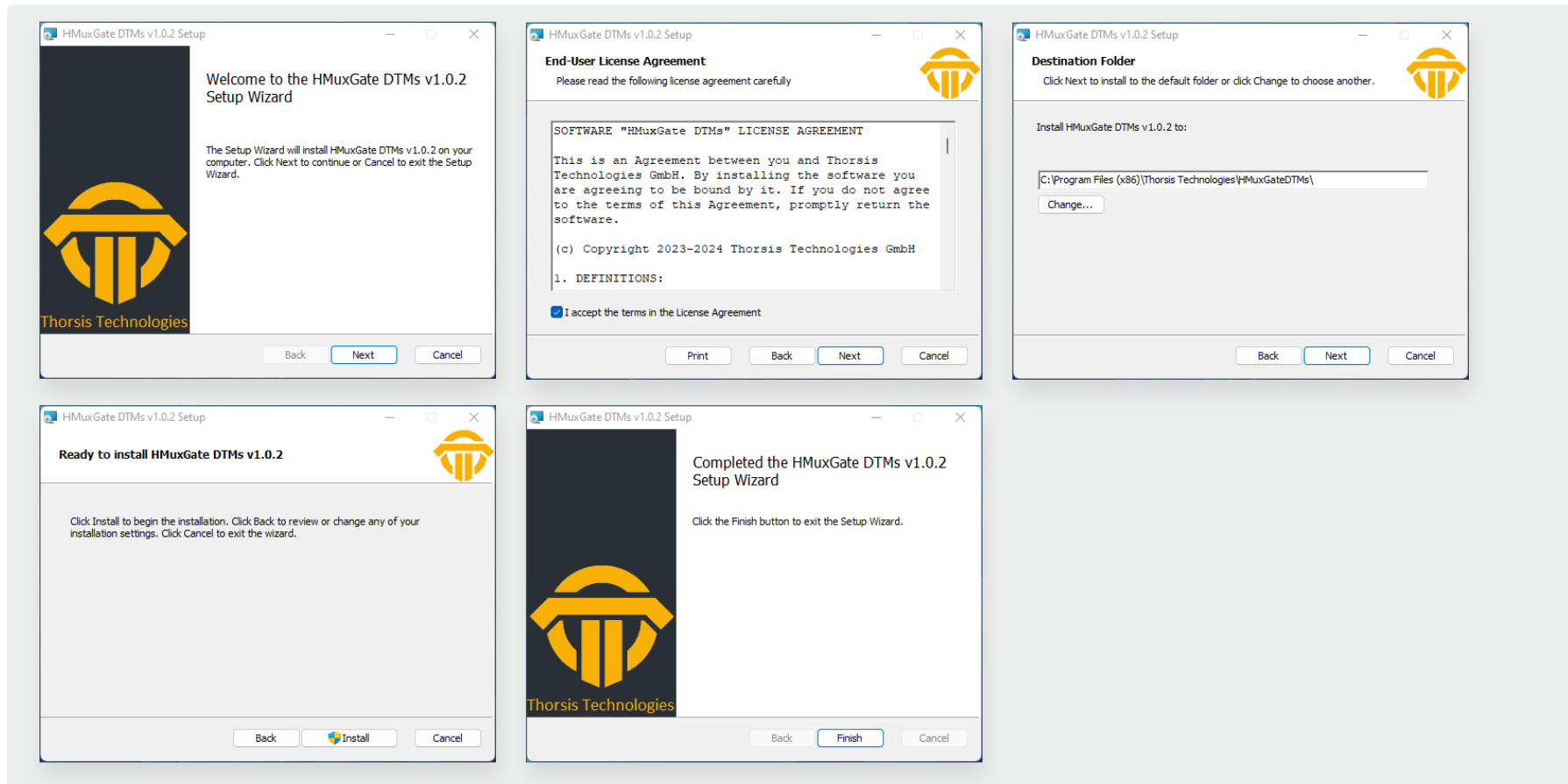

## 5.2 Start FDT Frame and update the device catalog



## 5.3 Insert the HMuxGate

The FDT Frame Application PACTware is used in this manual as an example.  
Once you have opened your FDT Frame Application and started a new project you can add the HMuxGate as device.

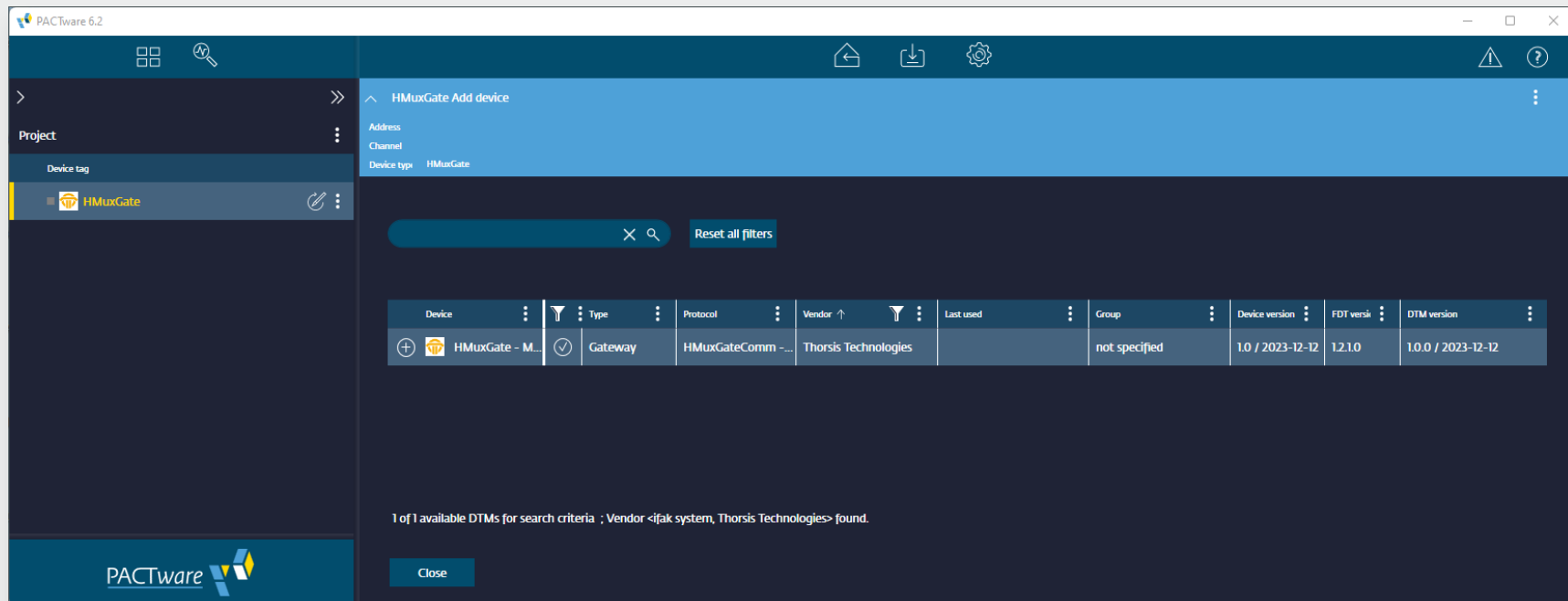

Before you can go online with the new device, you still need to enter the IP address of the isHMuxGate. In order to do so, select the Parameter menu item from the context menu.

The screenshot shows the PACTware 6.2 interface. A dialog box titled 'HMuxGate Add device' is open, with fields for 'Address', 'Channel', and 'Device type' (set to 'HMuxGate'). A context menu is open over a table of devices, with the 'Parameter' option highlighted. The table has columns for 'Type', 'Protocol', 'Vendor', 'Last used', 'Group', 'Device version', 'FDT vers', and 'DTM version'. A 'Close' button is visible at the bottom of the dialog.

Type	Protocol	Vendor	Last used	Group	Device version	FDT vers	DTM version
Gateway	HMuxGateComm -...	Thorsis Technologies		not specified	1.0 / 2023-12-12	1.2.1.0	1.0.0 / 2023-12-12

## 5.4 Enter the IP address

The DTM will automatically search the network for isHMuxGates.

If an HMuxGate is present in the network, it is displayed in the address bar of the parameter window.

If there is no isHMuxGate connected to the network, you can just enter the IP address manually into the address bar.

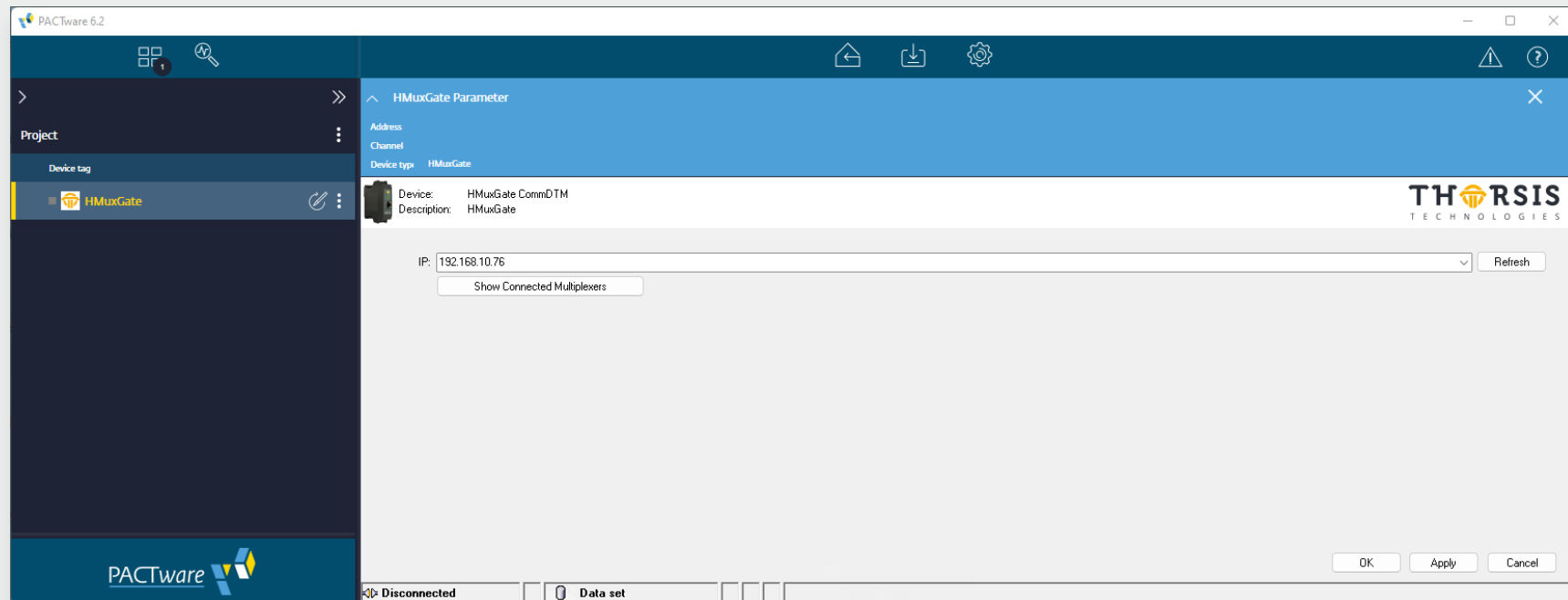

For informational purposes you can press the button (Show Connected Multiplexers).  
This will present a list of all HART multiplexers currently connected to the selected isHMuxGate.

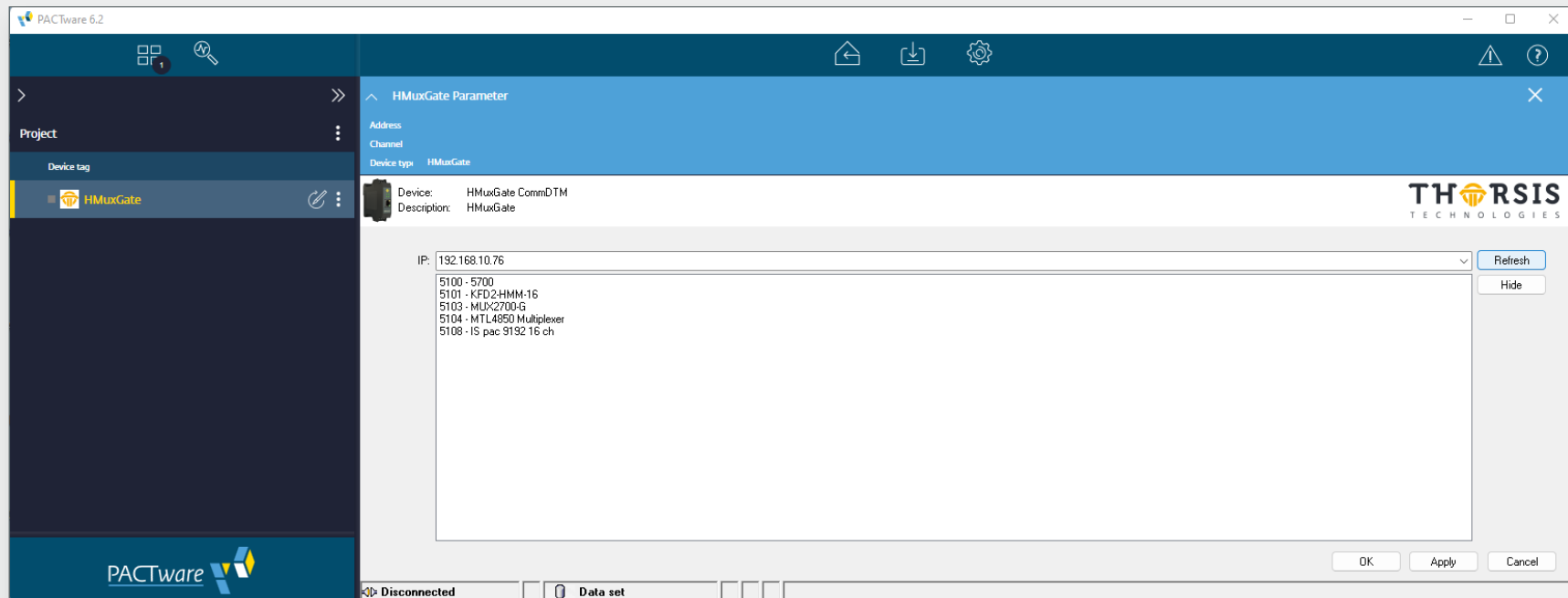

## 5.5 Topology Scan

With the help of the Topology scan, all connected multiplexers are displayed. The modules/channels are also searched for connected devices.

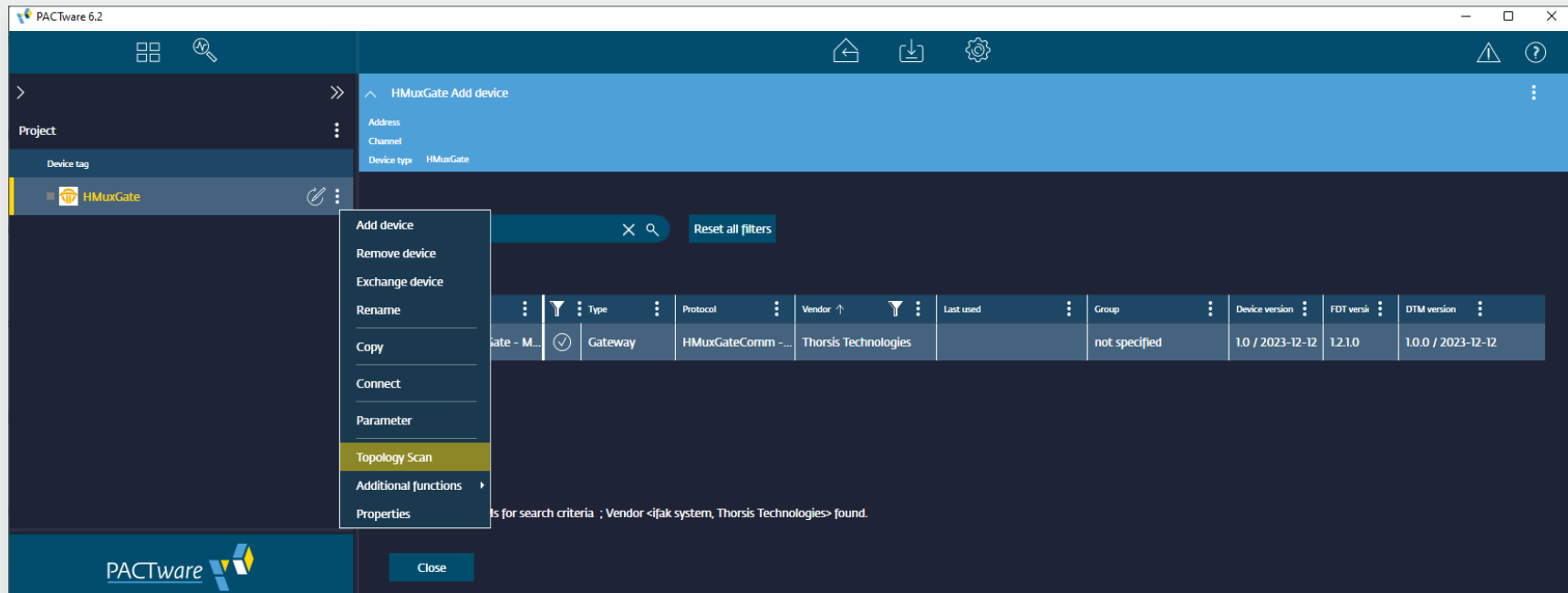

## 5.6 Offline view and Online view

If the appropriate device DTM is installed, you can work with the device DTM offline or online as usual.

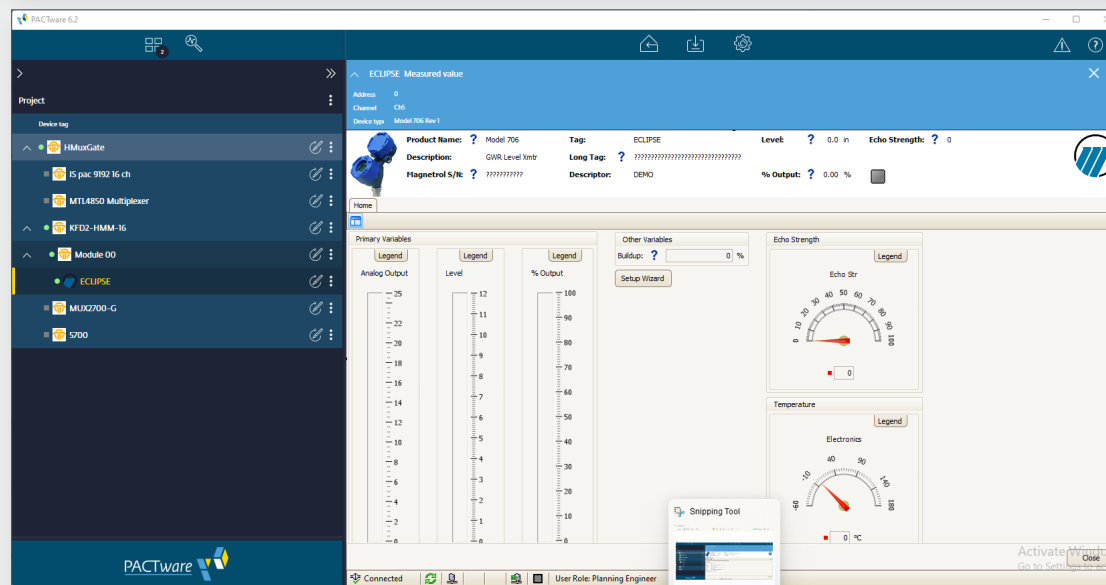
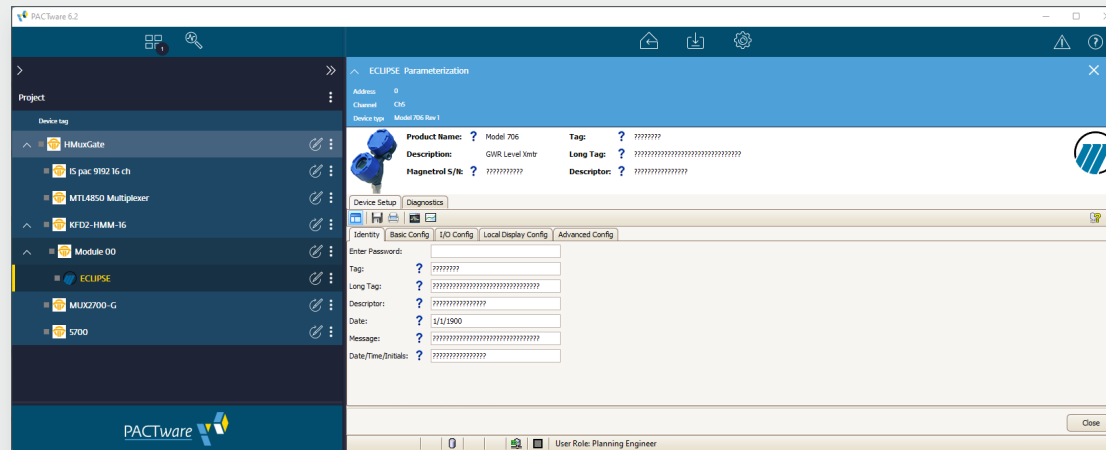

---

## 6. Document History

Version	Date	Description
1.0	05.25.2023	initial version
1.1	02.20.2024	adding ABB-FIM Configuration
1.2	03.12.2024	adding FDT DTM Configuration
1.2.5	10.29.2024	layout adjustments

© last change on 29. April 2025